

PUMP TECHNOLOGY

Screw Pumps & Systems



PUMP TECHNOLOGY

With experience and passion

» We do not only offer pumps, above all, we offer a tailor-made solution for our customers' requirements! «

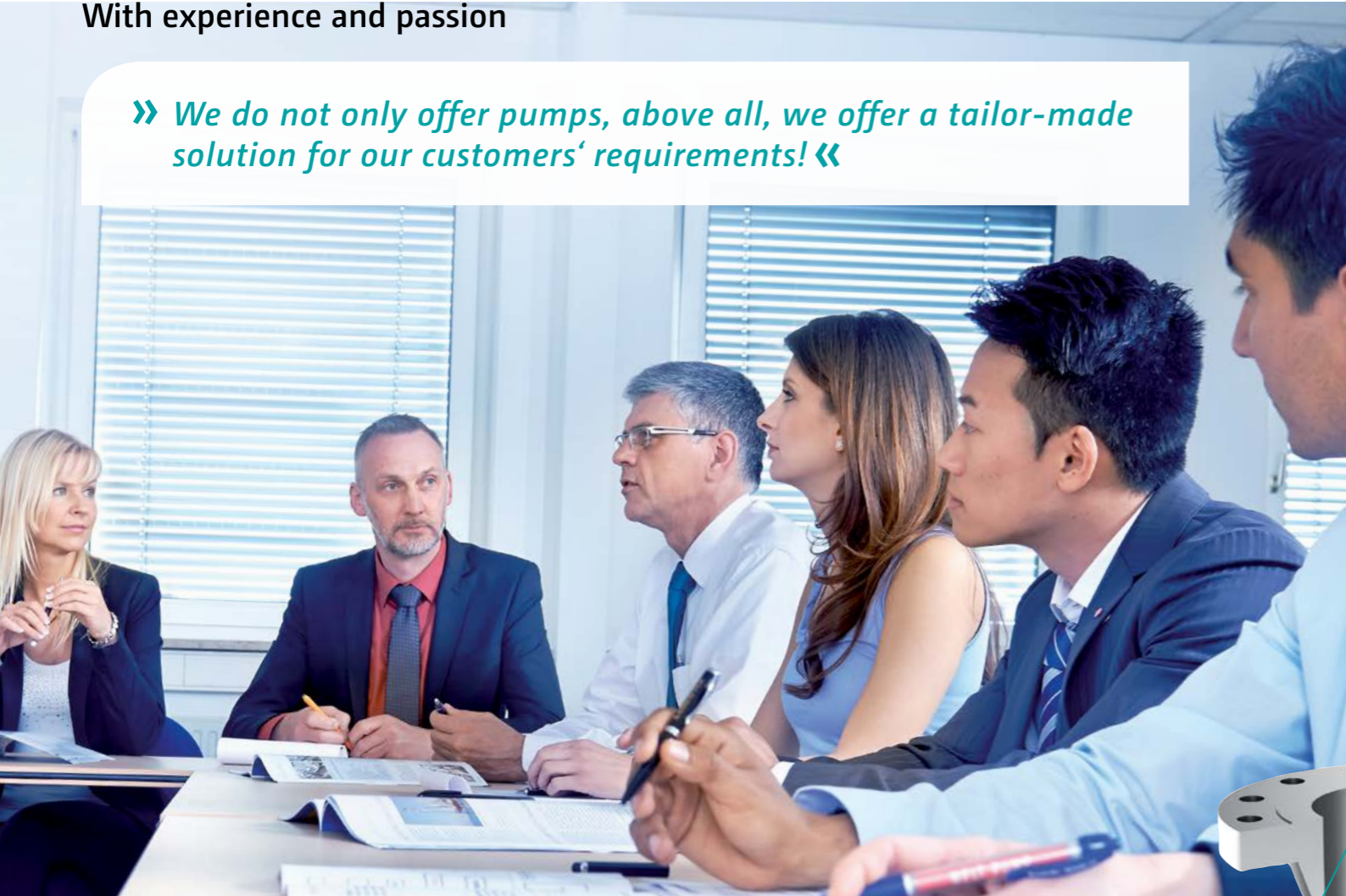

Leistriz is the first address when it comes to the application of screw pumps. After all, the company, with its headquarters in Nuremberg, is one of the pioneers in the field of screw pumps: 90 years ago, it was Paul Leistriz, who used the twin screw pump for the first time to pump lube oil for steam turbine bearings. What started out small in 1924 is now a globally active company with more than 300 employees, which has the widest product range in the field of screw pumps. Leistriz Pump Technology has branches in all important markets, such as the USA, China, Singapore, Dubai, India and Italy. Leistriz customers benefit from valuable know-how in various industries and applications.

SCREW PUMP

Superior technology & intelligent design

Leistriz pumps are based on a method that has been successfully used for more than 2,000 years: the Archimedes Principle. The combination of this successful idea in conjunction with 21st century know-how results in state-of-the-art pumps with optimum degrees of efficiency - for virtually any application.

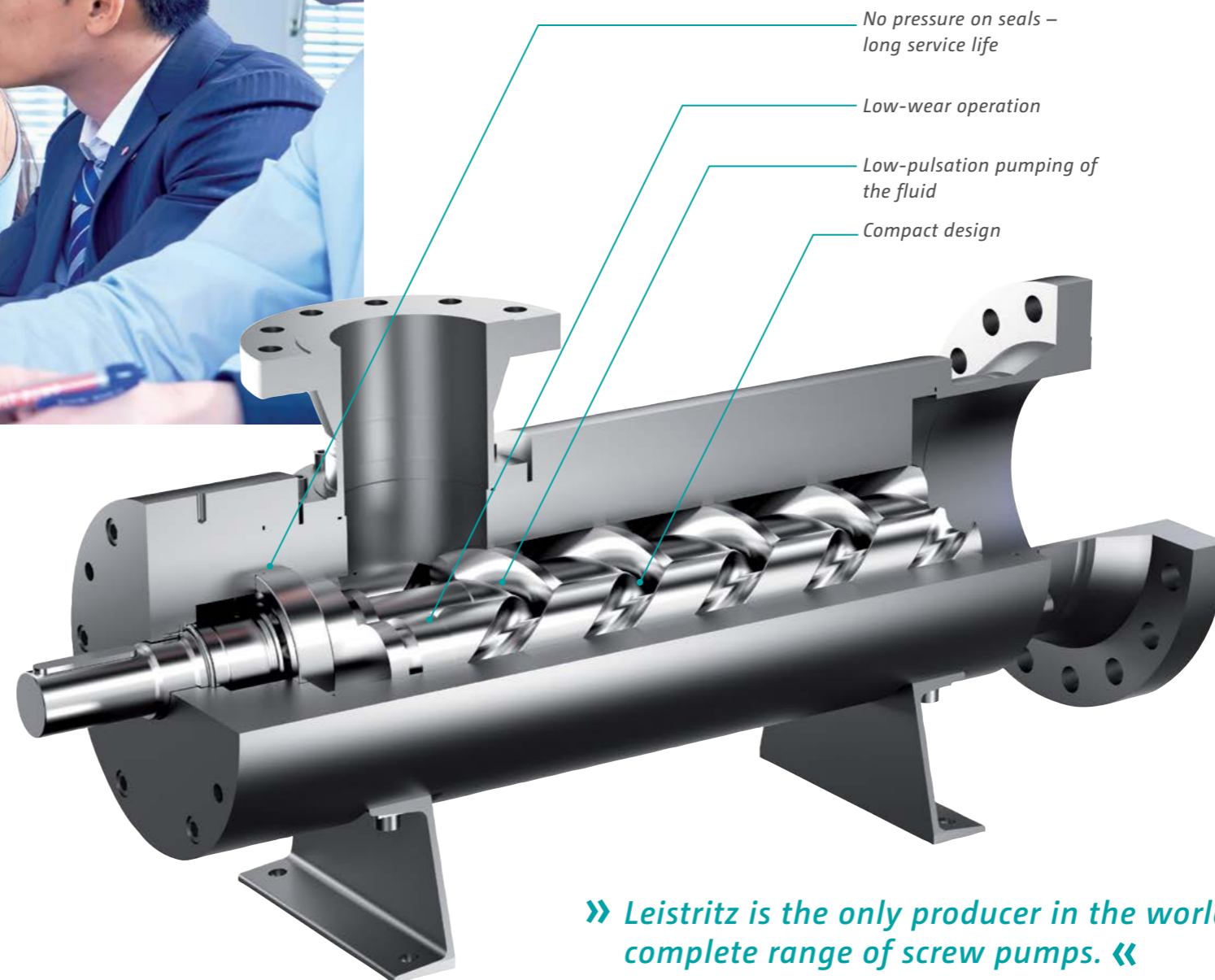
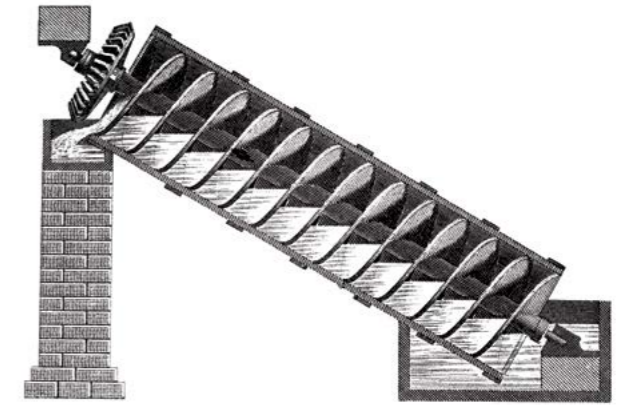

- No pressure on seals – long service life
- Low-wear operation
- Low-pulsation pumping of the fluid
- Compact design

PUMP FACTS

- The intelligent design of the Leistriz screw pumps offers enormous advantages over other pump technologies, like:
- » low-pulsation pumping of the fluid
 - » extremely low vibration and noise
 - » high flow rates
 - » pumping a wide range of viscosities
 - » low-wear operation
 - » long service life

» Leistriz is the only producer in the world to offer the complete range of screw pumps. «

AT HOME IN MANY INDUSTRIES

Customized solutions

» *Screw pumps by Leistriz can be found in numerous branches of industry. We offer our customers tailor-made solutions for the respective market requirements - ranging from the individual pump to the complete system.* «

ENERGY/POWER SYSTEMS

Leistriz screw pumps are used in power plants. Our twin and triple screw pump series are e.g. used for large diesel engines as main lube oil pumps or diesel supply pumps, as well as lube oil pumps for gear boxes, turbines and compressors.



LUBE OIL SYSTEMS

The protection and lubrication of bearings, drive units and gear wheels is crucial for the smooth-running and long-term operation of systems and machines. We offer twin and triple screw pumps with submerged, direct driven or horizontal design to fulfill all customer needs in terms of space requirements and operating data.

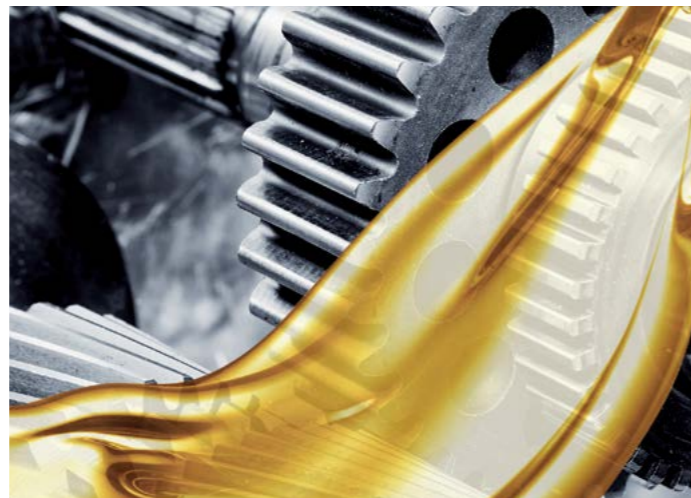

CHEMICALS/PETROCHEMICALS

Screw pumps in petrochemical and chemical process technology function as positive displacement pumps for the entire range of viscosity. Therefore, they are particularly suitable for this industry. Especially in chemical applications, the gentle handling of the pumping fluids with low shear forces on the product, as well as the optional use of a magnetic coupling as sealing, are the outstanding features for this type of pump.



OIL & GAS

Due to the large product range of single volute (L2, L3, L5) and double volute (L4) screw pump series, we are able to supply customized screw pumps and systems for virtually any application in the oil & gas industry: whether it is for pumping in crude oil production (upstream), crude oil transport (midstream) or for refinery processes (downstream).



SHIPBUILDING

Pump units and systems in use for ships must be energy-efficient and economical, but always also take account of climate protection and environmental considerations. Leistriz has been meeting these requirements very successfully for decades. Our screw pumps are well-known in the market for their robustness, quality and long service life. We are specialists when it comes to customized solutions for all shipbuilding applications.



AUTOMOTIVE

In its smallest version, the screw pump is used as a fuel pump for cars and as a volumetric meter at gas stations. Being a supplier for the automotive sector, Leistriz is constantly working on the further development of its products and thereby fulfills the high quality standards required in this efficiency-oriented and fast-moving industry at all times.



LEISTRITZ PUMPS IN OPERATION

Versatile and proven



PUMPS FOR OIL PRODUCTION

Multiphase systems are used successfully worldwide for onshore and offshore applications. These systems are based on the technology of the double volute twin screw pump. Flow rates of up to 5,000 m³/h and differential pressures of up to 150 bar are possible. They can operate with variable suction pressure and high gas concentrations (GVF) of up to 100 %. Operators of oil platforms are convinced by the cost-efficient technology: Instead of separating oil, water and gas at the oil well and exporting the oil and gas through separate pipelines to the central production plants, the multiphase mixture is transported through a single pipeline. Due to the direct pumping of the multiphase fluid to the central processing plant, separators, crude oil treatment plants, pumps, compressors and storage tanks become unnecessary at the individual wells of the oil fields.



COMPARISON CONVENTIONAL CONCEPT VS. MULTIPHASE CONCEPT

CONVENTIONAL CONCEPT

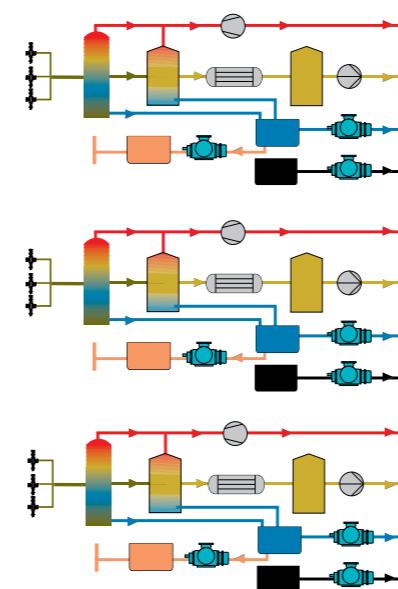

MULTIPHASE CONCEPT

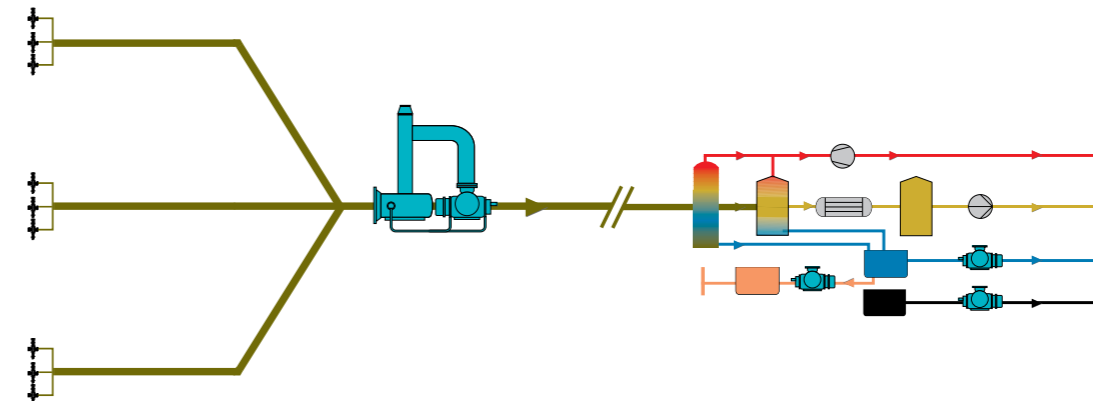

- Multiphase Well Flow
- Oil
- Gas
- Water
- Chemicals
- Slops & Drains
- Leistriz Multiphase Pump

LEISTRITZ PUMPS IN OPERATION

Versatile and proven



PUMPS IN TANK FARMS

Numerous oil-based products are transported from tank farms to ships, trains and trucks. Mainly L4 pumps are used for this purpose. In one of the most important tank farms in the world in Singapore, 32 of the Leistriz screw pumps have been operating for years. They load ships that transport semi-finished and finished products that are already pre-refined (so-called black and white products). The double volute twin screw pump conveys fluids at up to 5,000 m³/h with viscosities of up to 150,000 cSt. They particularly stand out by operating with low-pulsation and low-vibration.

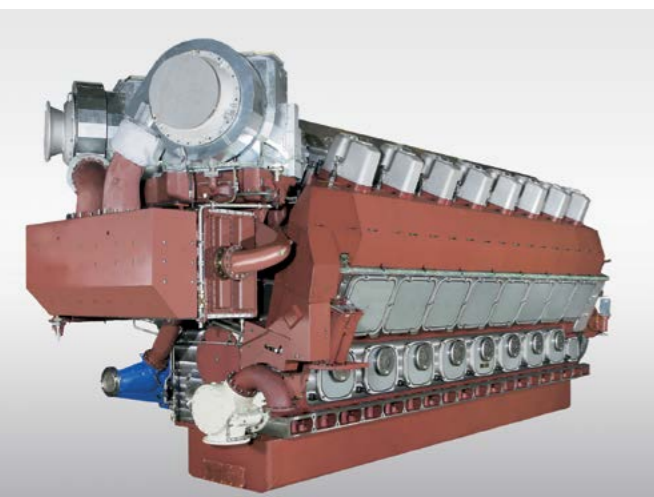

PUMPS FOR LUBE OIL SUPPLY

On the one hand, the lube oil supply of a diesel engine requires pumps with a high flow rate (up to 700 m³/h). On the other hand, they should require as little space as possible, be robust and have a long service life. The L3 pump by Leistriz fulfills all of these requirements – being a self-priming displacement pump for the low-pressure range of up to 16 bar. It is designed to be mounted directly to the diesel engine. The pipework and flange connections are tailor-made and designed precisely for this.



PUMPS IN THE CHEMICAL INDUSTRY

Operators of chemical plants have already been relying on L2 pumps since the 1960s. These are designed as a modular system and can be adapted to operating conditions by combining individual components. For a polyether product in a West German chemical plant, a L2 pump was designed and implemented with extremely sophisticated materials. A special ceramic coating was used for spindles and bearings, which guaranteed a problem-free flushing operation. The outstanding design ensures a accordingly longer service life. Without changing the construction, they can also be operated in a reversed flow direction for emptying the pressure lines.



PUMPS FOR SHIPBUILDING

On tankers that transport crude oil, fuel, asphalt or bitumen, pumps must be able to fulfill various pumping tasks: From unloading processes, circulating and mixing tasks, to draining and residual operation. For such applications, Leistriz offers the L2 or L5 pumps with only one shaft seal to the atmosphere. Specifically for unloading tankers with larger tank depths (> 7-8 m), Leistriz designed the submerged „cargo pump“, which is in operation in various versions on many ships. It is installed in a separate pipe on board in the aft of the tanks. The „cargo pump“ has an outstanding design: With the inlet level of the installation pipe being situated above the actual pump inlet, it is ensured that the pump is sufficiently immersed in the product, even at low filling levels of the tank.

PUMP OVERVIEW

For various applications and flow rates

» Leistriz offers twin, triple and quintuple screw, self-priming positive displacement pumps in a single or double volute version for a wide pressure range. They are used for pumping various fluids with different viscosities. «

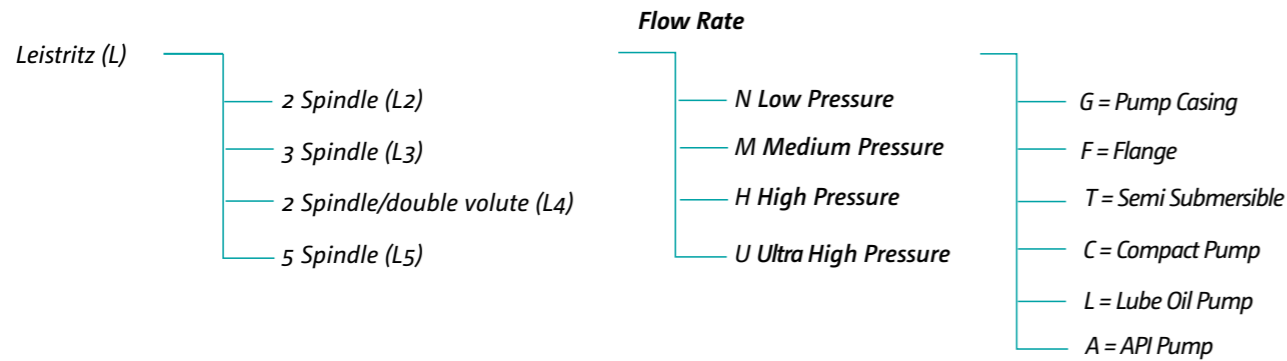
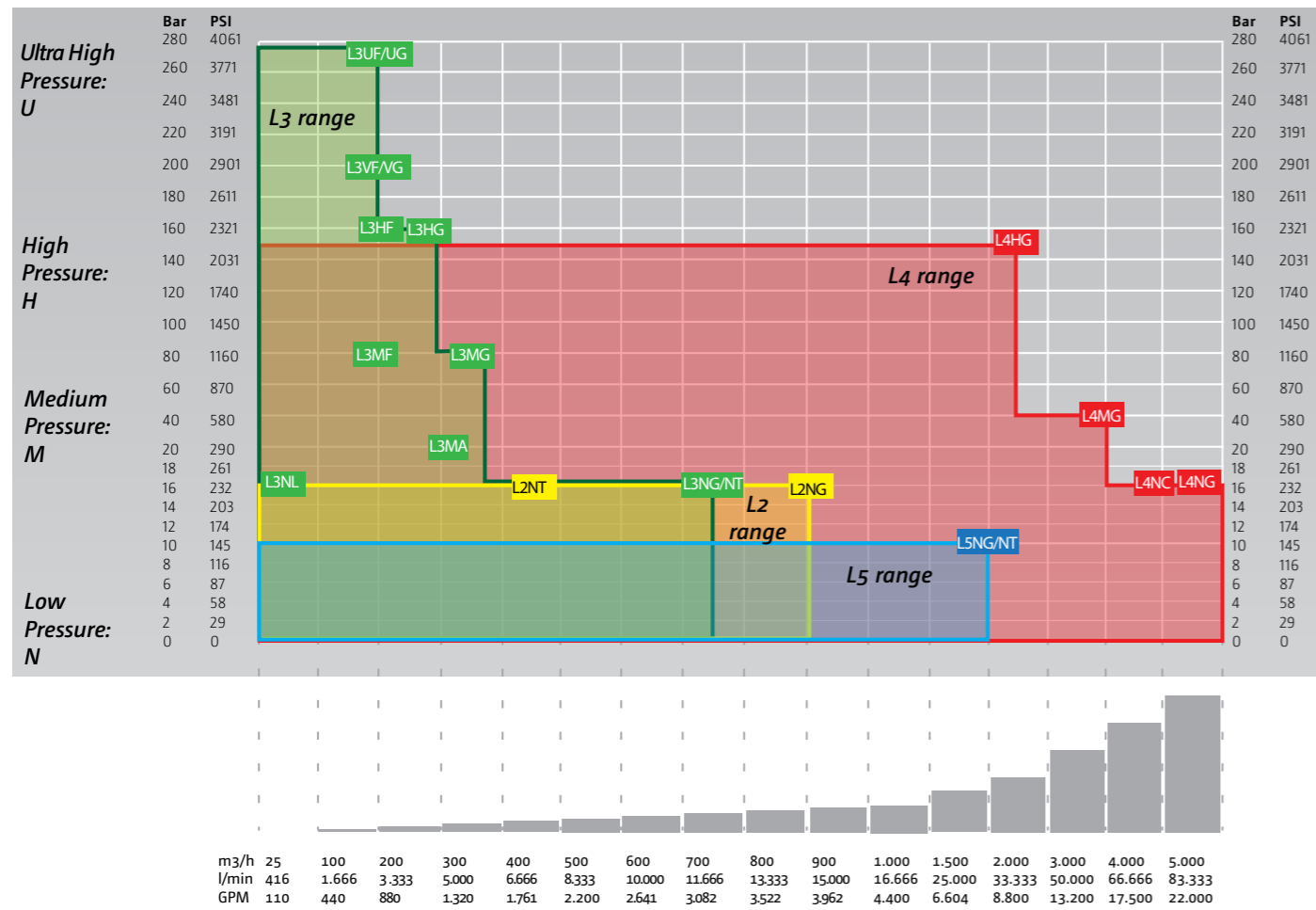

PUMP PROGRAMM

SERIES	USE FOR	PUMP TYPE	PERFORMANCE DATA			
			Capacity	Pressure	Viscosity	Temperature
L2N	Low pressure duty, suitable for transport of light abrasive and corrosive, high or low viscous fluids with poor or good lubricity.		900 m³/h 3,960 gpm	16 bar 232 psi	100,000 cSt	280°C 536°F
L3N	Low pressure duty, suitable for transport of non-abrasive lubricating fluids.		700 m³/h 3,100 gpm	16 bar 232 psi	15,000 cSt	180°C 356°F
L3M	Medium pressure duty, suitable for transport of non-abrasive lubricating fluids.		300 m³/h 1,320 gpm	80 bar 1,160 psi	10,000 cSt	280°C 536°F
L3H L3V L3U	High and ultra high pressure duty, suitable for transport of non-abrasive, light abrasive and corrosive, high or low viscous fluids with poor or good lubricity.		200 m³/h 880 gpm	280 bar 4,060 psi	10,000 cSt	280°C 536°F
L4N L4M L4H	Low, medium and high pressure duty, suitable for transport of abrasive/non-abrasive, corrosive/non-corrosive, lubricating/non-lubricating, high or low viscous fluids.		5,000 m³/h 22,000 gpm	150 bar 2,175 psi	150,000 cSt	350°C 662°F
L5N	Low pressure duty, suitable for transport of light abrasive and corrosive, high or low viscous fluids with poor or good lubricity.		1,700 m³/h 7,500 gpm	10 bar 145 psi	100,000 cSt	280°C 536°F

This list offers a general overview of the standard pump range by Leistriz. Various options and systems are individually configured according to customer requirements and tested on our test bench (drive power up to 4 MW) in Nuremberg.

MANUFACTURING KNOW-HOW

Pumps: Engineered & Made in Germany

» *Leistriz pumps are manufactured with expertise and passion.* «



Rising demands on pump manufacturers regarding wear protection, service life or flow rate require the use of state-of-the-art machine technology and process chains that are ideally coordinated with one another. These are the prerequisites to facilitate the high-quality manufacturing of pump components. To accomplish this high standard, we produce the screws and housings, i.e. the core elements of the Leistriz pumps, ourselves in Germany - under the aspect of the ultimate precision and with a high level of production knowledge vertical integration. This is particularly due to the symbiosis of the various products

of the Leistriz Group in the form of superior materials know-how and in-house metal processing technologies, such as whirling. In addition to our numerous machines, it is particularly our team that convinces our customers with its well-founded expertise and extensive manufacturing know-how.

We are constantly working on improving our products and processes. In the market, Leistriz stands for precision, quality, operating safety and durability. Not only do we invest in state-of-the-art production facilities, but also in the knowledge of our employees. Ongoing training courses are therefore a fixed part of everyday life at Leistriz. This is the only way to guarantee a high level of quality.

CUSTOMER SERVICE

Our qualified service team is available to our customers 24 hours a day with advice and assistance.

Leistriz Service Hotline: +49 911 4306-690

Leistriz Pumpen GmbH is certified according to all of the well-known standards.



SERVICE & QUALITY

More reliability and durability

Our pumps are in operation worldwide. They have to satisfy the highest production and quality requirements every day. For the technology to continue functioning reliably after several thousand operating hours, adequate servicing, the use of original spare parts and particularly also the right advice are essential.

» *When it comes to quality, we make no compromises.* «

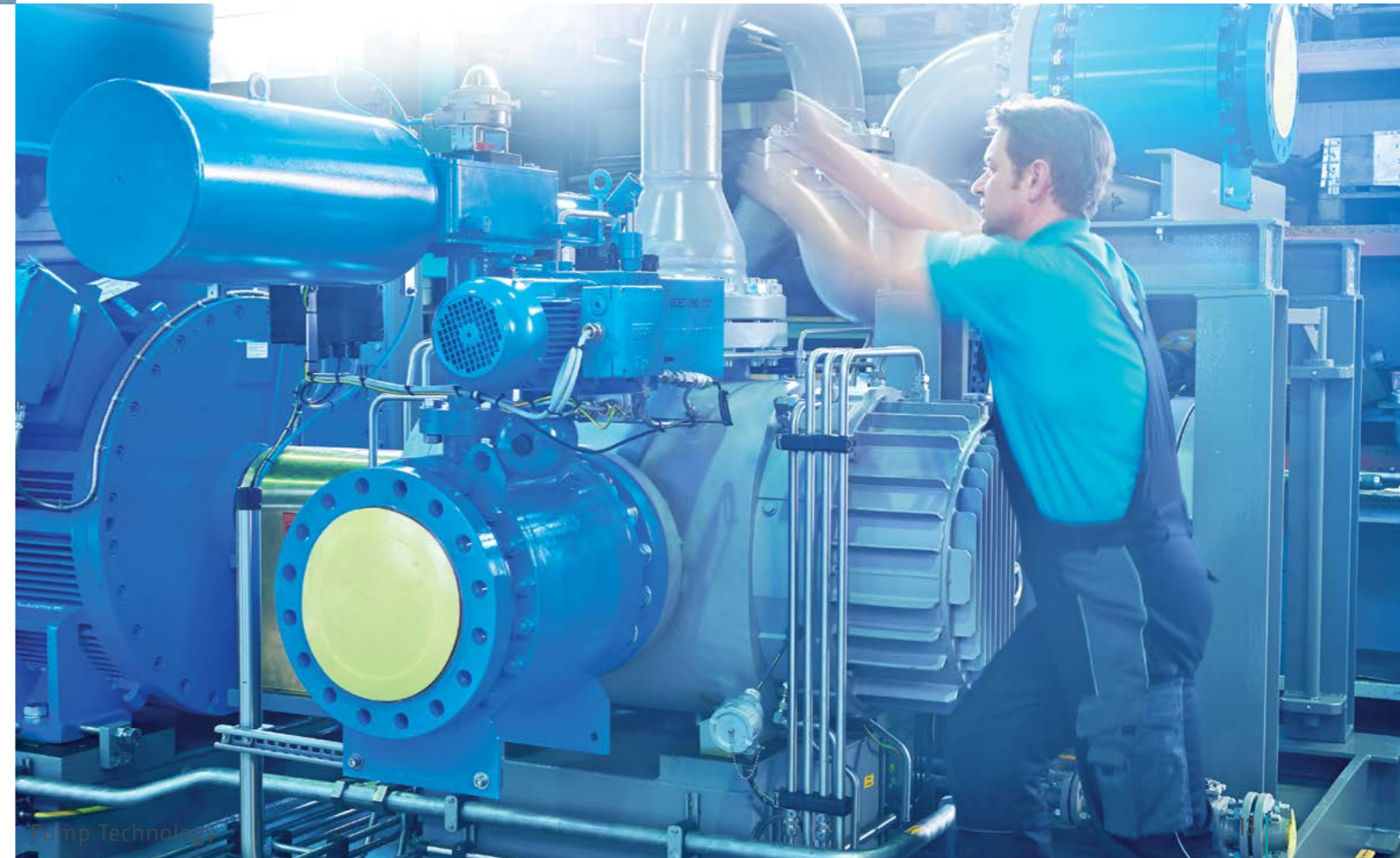

RESEARCH & DEVELOPMENT

Ideas for the future



In the area of research & development, we are concentrating on topics such as increasing efficiency, using new materials and optimizing components. After all, increasingly higher demands are being placed on pump systems. An important part of the Leistriz philosophy is to be actively involved in structuring the future of the pump sector with new ideas and findings. We also do this with institutes, universities and cooperation partners.

Within the context of a research study, we are the world's only screw pump manufacturer to have succeeded in developing a simulation with which the flow of a „working“ pump can be calculated with defining the most important operating parameters. Our goals were to improve the degree of efficiency and the suction properties, as well as to increase the energy efficiency. We are able to test the theoretical results on our own test bench in Nuremberg. It offers the optimum opportunity to put our pumps to the test under realistic conditions.

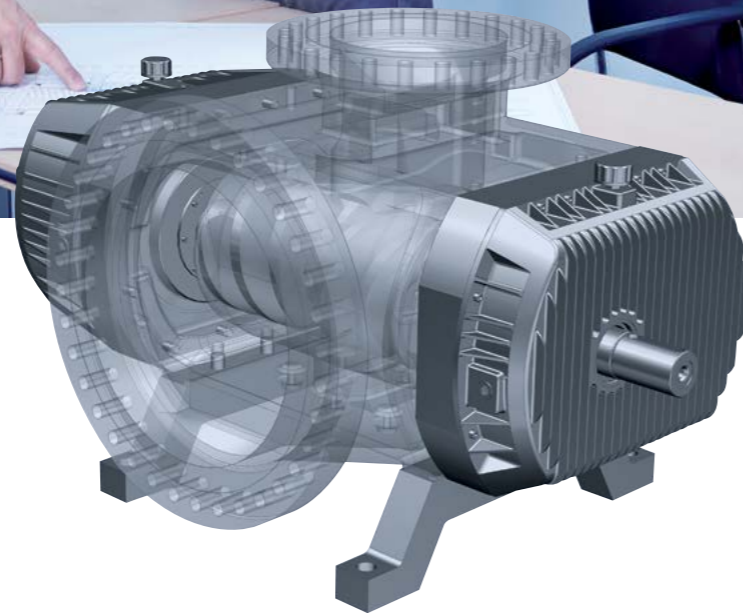

LEISTRITZ GROUP

One company - dynamic, innovative, reliable and collaborative

The special thing about Leistriz: It was founded in 1905 as a family enterprise. We are still an owner-operated company today, in which dynamic further development and innovative solutions count and values such as reliability and partnership are embodied.

With turbine blades for the aviation and aerospace industry, screw pumps for sectors such as oil and gas,

the chemical industry and shipbuilding, twin screw extruders for the plastics and pharmaceuticals industry, as well as tools/machine tools for the automotive industry and mechanical engineering, we offer an extremely wide range of solutions. The high level of expertise in products and technology has always been the basis of our success. We employ approx. 1,900 staff in the various locations worldwide.

» Four business units - one motion: rotation «

TURBINE TECHNOLOGY
Blades for Turbines and Compressors



PUMP TECHNOLOGY
Screw Pumps and Systems



EXTRUSION TECHNOLOGY
Extruders and Extrusionlines



PRODUCTION TECHNOLOGY
Tool Machines, Machine Tools and Tube Technology

PUMP TECHNOLOGY

Available for you all over the world

